

QUALITY ASSESSMENT OF PHARMACY AND INTERNET OBTAINED TOPICAL TESTOSTERONE FORMULATIONS

B. Baert, V. Vergote and B. De Spiegeleer*

Drug Quality & Registration (DruQuaR) group, Faculty of Pharmaceutical Sciences, Ghent University, Harelbekestraat 72, B-9000 Gent, Belgium; *Corresponding author: Bart.DeSpiegeleer@UGent.be. [2007-374b]

Introduction

Testosterone, a steroid hormone from the androgen group, is among the oldest marketed drugs, with a long record of safe and effective use for its principal indication of testosterone replacement in androgen deficient men. However, over recent decades, testosterone and other androgens have increasingly been used as drugs of abuse, complete with an illicit market and their own folklore.

Objective

The aim of this study was to perform a comparative chemical quality evaluation of topical testosterone formulations, both obtained from a hospital pharmacy and via the internet.

Experimental

• Formulations

Six different formulations were analyzed. Formulations 1 to 4 were authorized pharmaceuticals obtained from a hospital pharmacy, while formulations 5 and 6 were purchased via the internet.

• Liquid chromatography

Assay of testosterone was done by validated HPLC-UV. The HPLC apparatus consisted of a Waters Alliance 2695 separations module and a Waters 2996 photodiode array detector (all Waters, USA). LC separations were performed using a Lichrospher 100 RP18 (125 mm × 4 mm, 5 µm particle size) column (Merck, Darmstadt, Germany) thermostated at 30°C, with a mobile phase consisting of a mixture of (A) 0.1% m/V formic acid in water, and (B) 0.1% m/V formic acid in acetonitrile. The flow rate was set at 1.0 mL/min. UV detection was done at 254 nm.

Related impurities were determined by LC-DAD/ESI ion trap mass spectrometry. The LC-DAD/MS apparatus consisted of a SN4000

interface, a SCM1000 degasser, a P1000XR pump, an AS3000 autosampler and a LCQ Classic ion trap mass spectrometer (all Thermo, USA) equipped with a Waters 2996 photodiode array detector (Waters, USA). The method used was based upon the assay for related impurities of testosterone described in the European Pharmacopeia 5.0 (Ph.Eur). LC separations were performed using a Lichrospher 100 RP18 (125 mm × 4 mm, 5 µm particle size) column (Merck, Darmstadt, Germany) thermostated at 40°C, with a mobile phase consisting of a mixture of (A) H₂O/methanol (45:55, V/V), and (B) pure methanol. The flow rate was set at 1.0 mL/min.

• Dissolution tests

Biopharmaceutical properties were evaluated by an in-house developed 'paddle over disk' dissolution test (see Figure 1) using several physiologically relevant media: phosphate buffered saline (PBS), PBS + 0.5% bovine serum albumin (BSA), PBS + 0.5% hydroxy-propyl-beta-cyclodextrine (HPBCD), simulated sweat, simulated sweat + 0.5% HPBCD, simulated body fluid and simulated body fluid + 5% BSA. The membrane used to cover the formulations was a SpectraPor® dialysis membrane with a MWCO of 12-14000 Da.

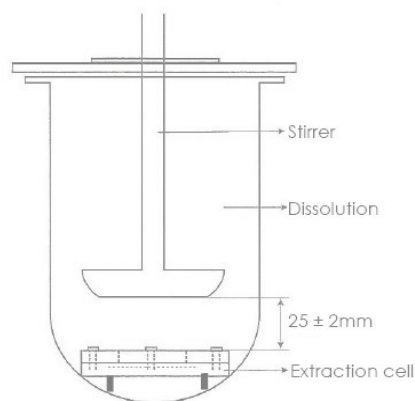

Figure 1: Paddle over disk dissolution test.

Results and discussion

• Assay of testosterone

Results for the assay of testosterone by HPLC-UV are given in Table 1. The testosterone content of formulations 1 to 5 was within specifications (95-105% of the label claim), while formulation 6 did not contain any testosterone at all.

Table 1

Formulation	Origin	Assay (% label claim)
1	Hospital	102.82 (\pm 0.98)
2	Hospital	101.38 (\pm 0.95)
3	Hospital	102.61 (\pm 2.20)
4	Hospital	102.66 (\pm 3.37)
5	Internet	102.18 (\pm 0.18)
6	Internet	Not detected ⁽¹⁾

⁽¹⁾ Detection limit = 0.15 μ g/g formulation.

• Related impurities

Reporting threshold (RT) for individual impurities was set at 0.05%. The identification and quantification threshold, defined as acceptance specification limit, was set at 0.20%, with the exception of the epimeric testosterone impurity (limit set at 0.50%), based upon the Ph. Eur. limits.

Results are given in Table 2. Based upon the relative retention times, the UV-spectrum and the mass spectrum, 2 of the impurities were identified: the first one was due to epimerization of testosterone and the second impurity consisted of oxidized forms of testosterone.

Table 2

Formulation	n ⁽¹⁾	Impurities (%)		
		Oxidised testosterone	Epimeric testosterone	Total peak area
1	3	-	-	0.11
2	3	0.07	0.28	0.41
3	7	0.05	0.41	1.01
4	8	0.12	0.28	1.45 \rightarrow 0.98
5	4	0.30	0.55	0.99
6	-	-	-	-

⁽¹⁾ n = number of impurity peaks above RT.

Formulation 4 was a patch and hence testosterone unrelated HPLC peaks due to patch extraction were observed, totalling 1.45%. The major peak of 0.47% was unambiguously identified by LC-DAD/MSⁿ as a patch compound, resulting in a maximal total peak area related to testosterone of 0.98%.

• Biopharmaceutical properties

The topical formulations were brought into an in-house developed extraction cell and a 'paddle-over-disk' dissolution test was performed. Typical curves obtained are shown in Figure 2.

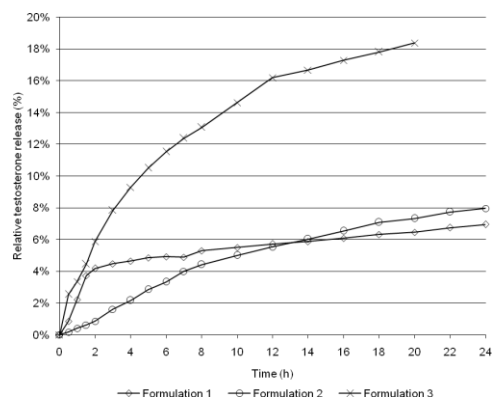

Figure 2: Dissolution curves obtained for formulations 1 – 3 using PBS + 0.5% BSA as medium.

Different dissolution profiles were obtained for the formulations, depending on the media used as well. The clinical relevance of these different biopharmaceutical behaviours remains to be elucidated.

Conclusion

While the majority of the formulations conforms the acceptance specifications defined, the two internet obtained products were not in compliance. Formulation 6 was presented as a pharmaceutical product, but did not contain testosterone at all. A too high impurity content was found in formulation 5 for the two identified impurities. The dissolution tests are promising as a valuable discriminating biopharmaceutical characterisation.

Acknowledgments

We thank S. Bodé and R. De Cock for their experimental help.